

Fusion3

ANVIL Print Head

CHANGING ANVIL PRINT HEAD TUBES

Revision 5/28/2022

ANVIL PRINT HEAD - CHANGING ANVIL PRINT HEAD TUBES

How to change print head tubes on the ANVIL print head

INTRODUCTION

One of the key features we're most excited about with ANVIL is its single-piece, easily-replaced filament path. This means if you encounter a print head jam, or if you experience degraded print quality, it's easy to replace this component and get the print head working like-new again.

The filament path in ANVIL is a thin-wall surgical steel tube with an integrated nozzle. There are no internal joints that could leak, break, or otherwise cause issues.

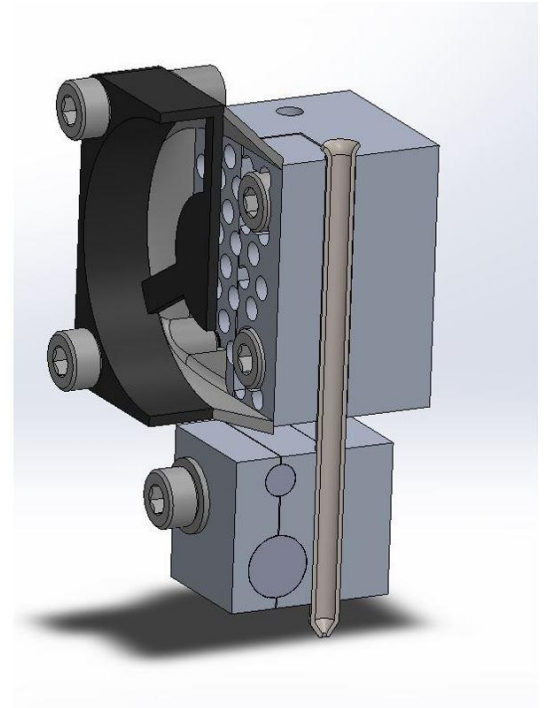

WHEN TO REPLACE AN ANVIL PRINT HEAD TUBE

- Replace the tubes as-needed; they are not replaced on a maintenance schedule.
- If you encounter a print head jam that you cannot clear
- If you experience poor or degraded print quality (stringing, gaps in infill, flow starvation, etc)
- As part of troubleshooting other print issues

REMOVING A TUBE

1. Unload filament from the print head, if possible.

2. While the print head is hot, use the brass wire brush included in your toolkit to clean the bottom of the hot section of the print head. Focus on the joint between the tube and the clamped sections. If there is plastic debris here it makes it more difficult to remove the tube.

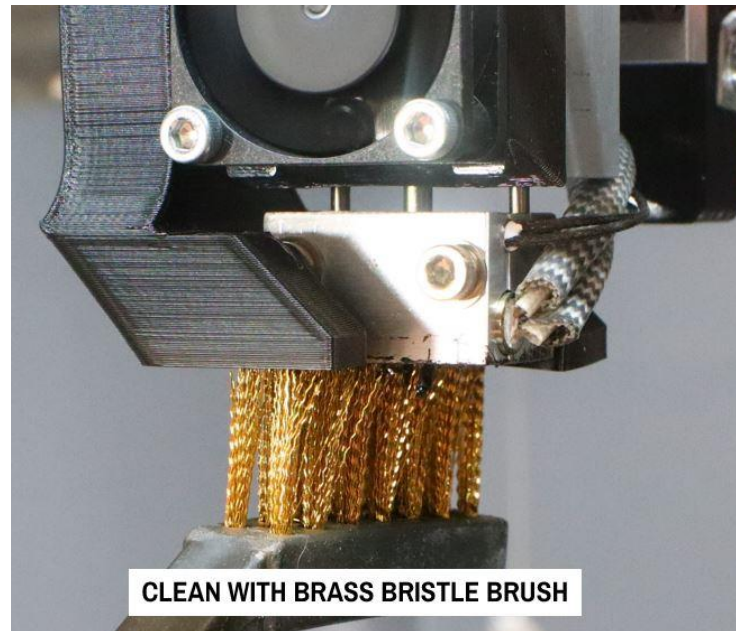

3. Wait for the print head to cool down to < 40 C.
4. Remove the top window.

5. (Optional) remove the blower, duct, and blower mount from the x carriage assembly to gain more room to work.

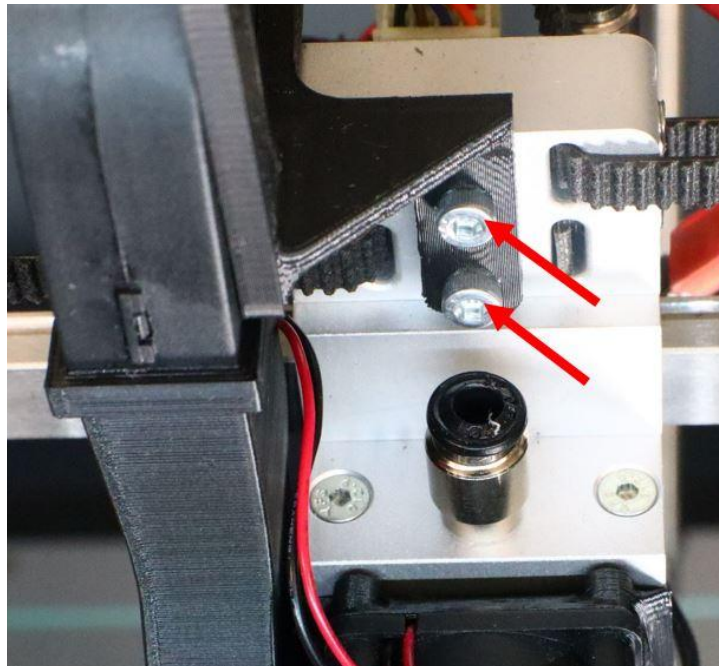

6. Remove the 30mm fan and duct by unscrewing the **bottom 2** screws in the fan.

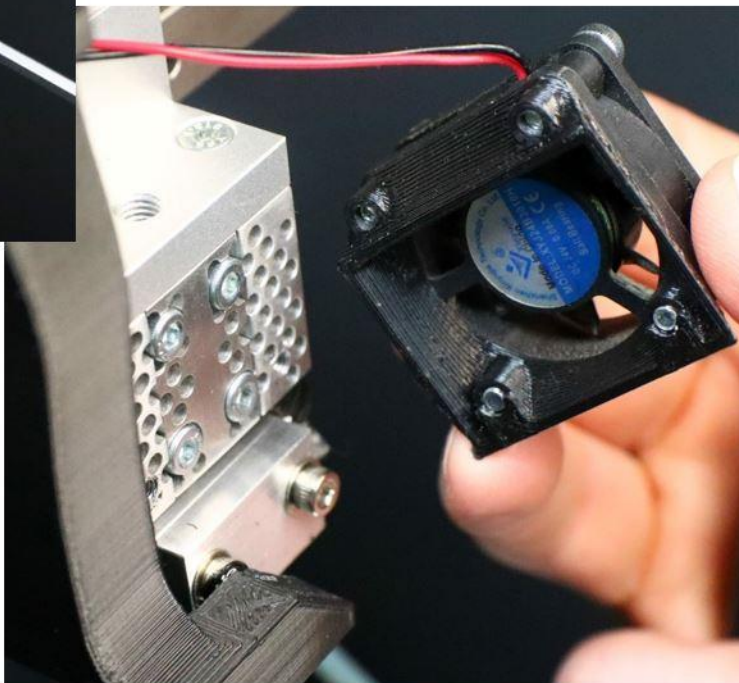
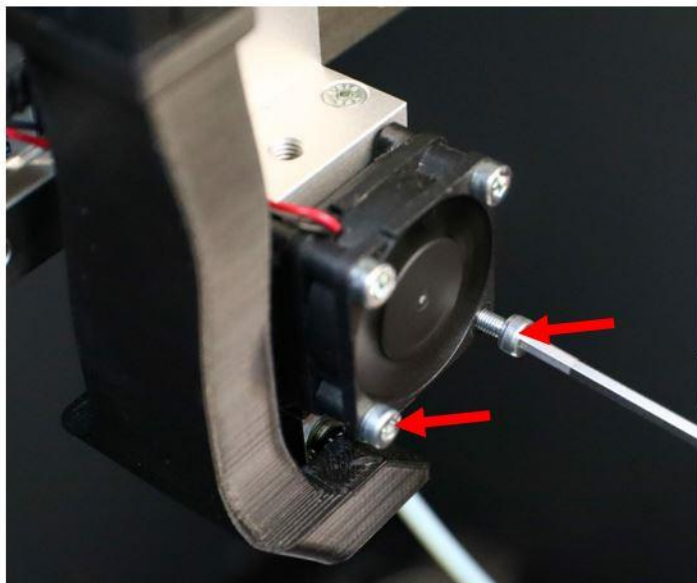

7. Loosen but do not remove the (2) hot side clamp screws and the (4) cold side clamp screws.

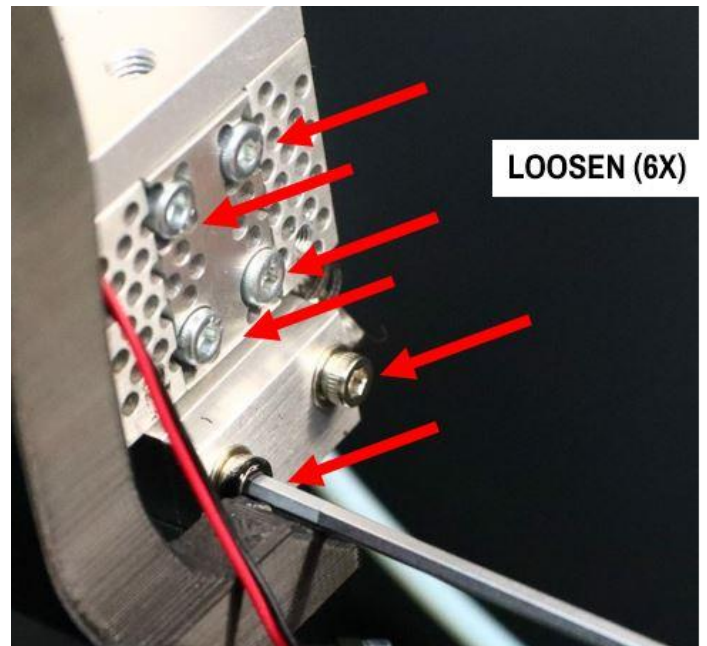

8. Remove the bowden tube from the PTC fitting above the print head.

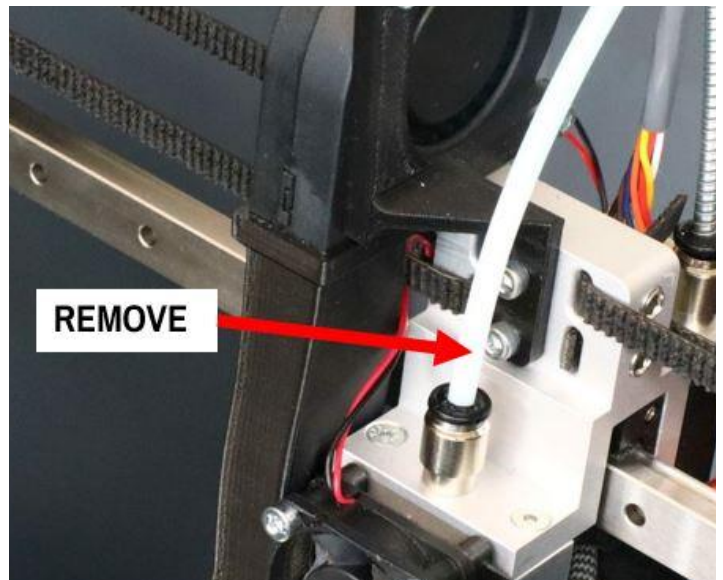

9. Unscrew the PTC fitting from the x carriage body using a 2.5mm hex drive.

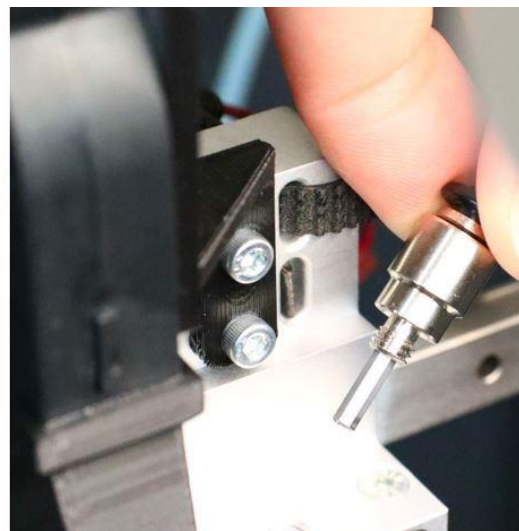
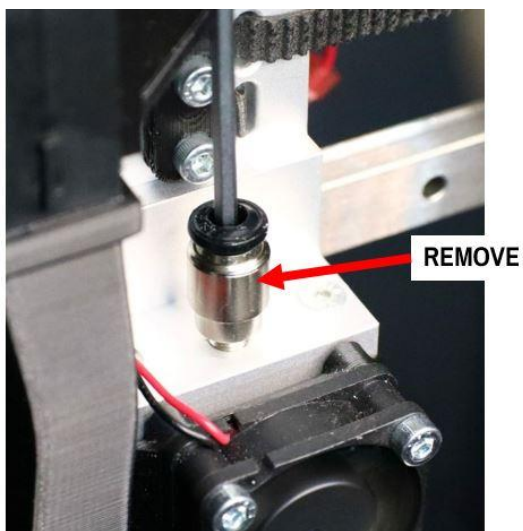

10. Push the tube out of the print head and up through the hole where the PTC fitting was. If the tube is stuck with plastic, sometimes you will need to use a flat metal tool to pop it loose. Then, finish removing it by using a hex key to push it up through the hole at the top of the print head.

IMPORTANT: The hot block and cold block are permanently joined together with the standoffs. Do not attempt to separate the two sections.

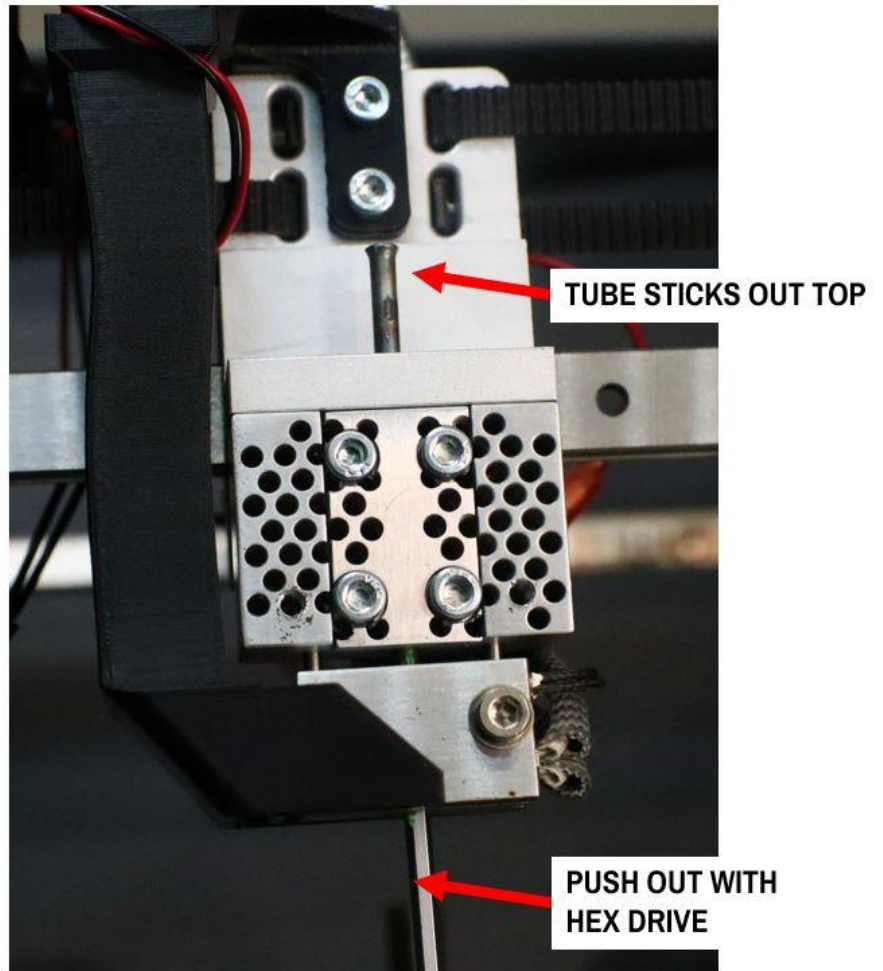
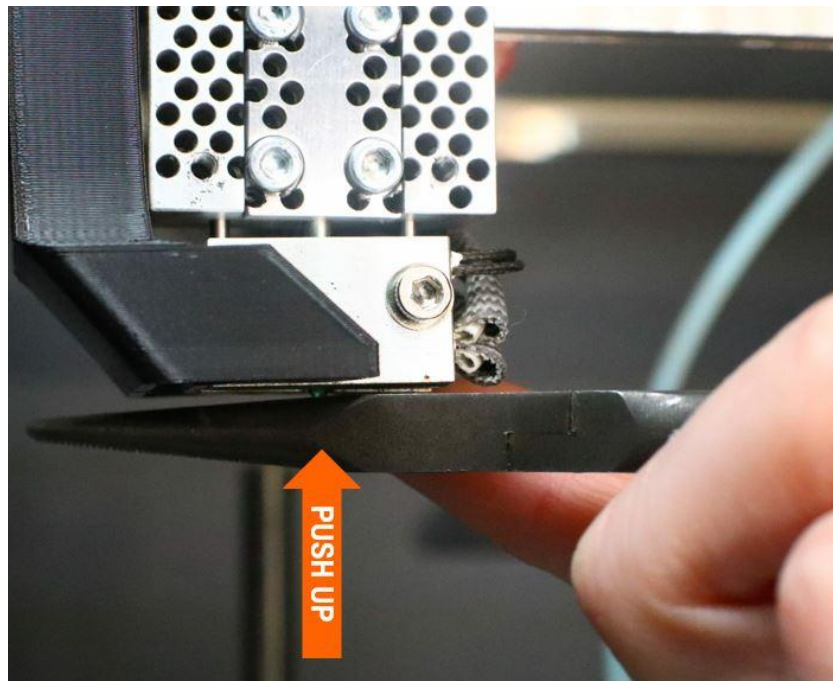

Troubleshooting

If the tube will not dislodge from the hot section, it may be stuck in place with some molten plastic.

A) Stuck-Tube Removal Method

1. Heat up the print head to 200C. Remember that the fan that cools the cold side is removed, so you want to do this procedure fairly quickly so you don't overheat the cold side.
2. As soon as the print head reaches 200C, gently push up on the bottom of the tube with a metal tool (such as pliers shown above). Hopefully the soft plastic will release and you can remove the tube.
 - a. If the tube does not release, proceed to the second method below.
3. Immediately turn off the print head.

B) (alternate) Stuck-Tube Removal Method

1. Remove the print head from the x carriage body by removing the (2) M3x10 FHCS.

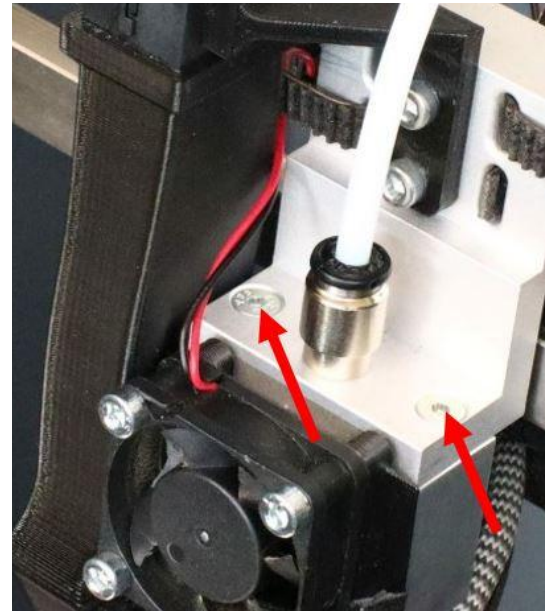

2. Take a spare M3 screw and thread it into the spare hole in the rear of the hot block. You should feel this screw bottom out. Turn it another ¼ to ½ turn to dislodge the hot section pieces from each other.

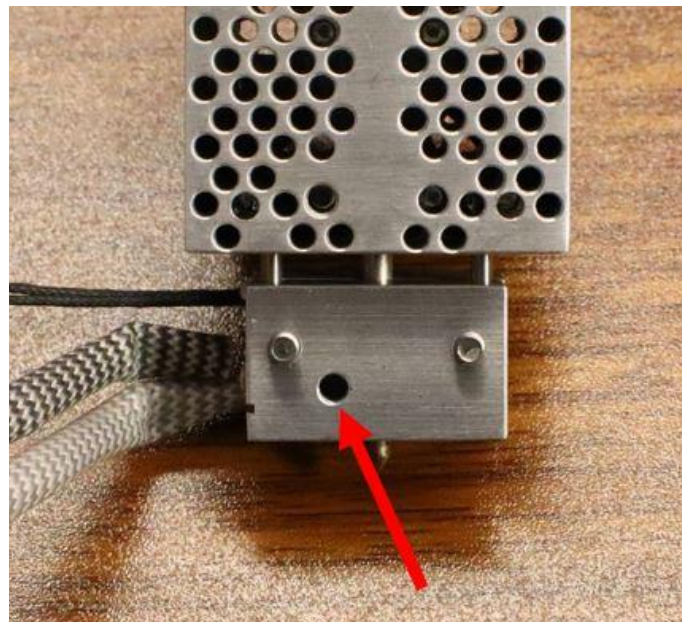

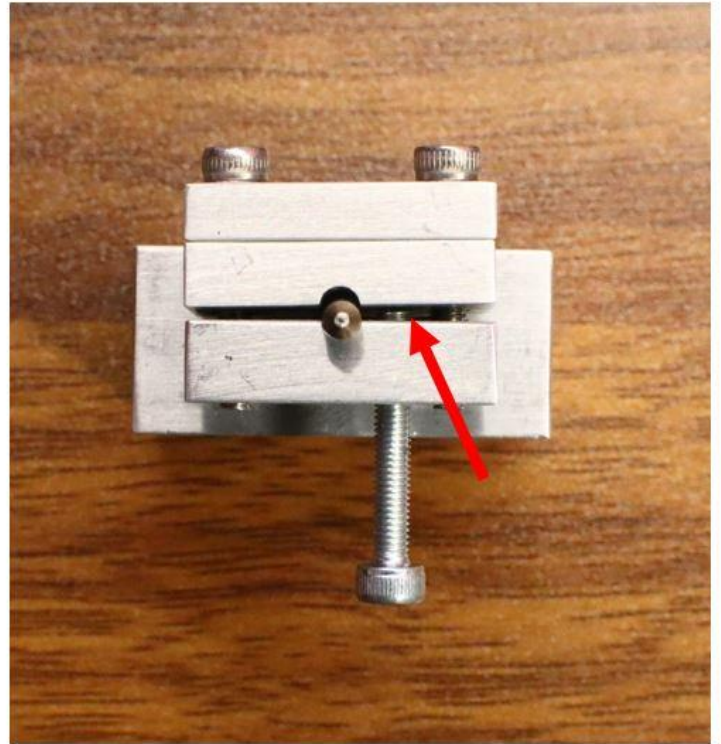
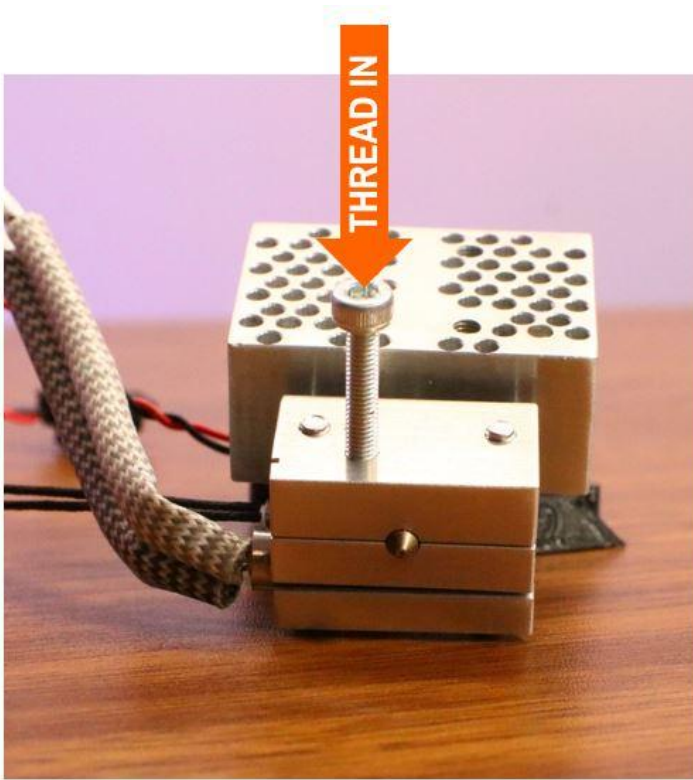

3. This should free the tube. If not, you can attempt to break the tube free by smacking it on a wooden surface such as a desk, plywood, or a 2x4. This will be soft enough to not damage the tip of the tube while still delivering enough force to pop it loose.
4. In order to do this you will need to completely remove the print head from the machine by disconnecting the electrical connectors for the sensor and heater power. These are the lower two connectors on the breakout board. You will also need to cut the wire retention zip tie on the side of the bed probe body.

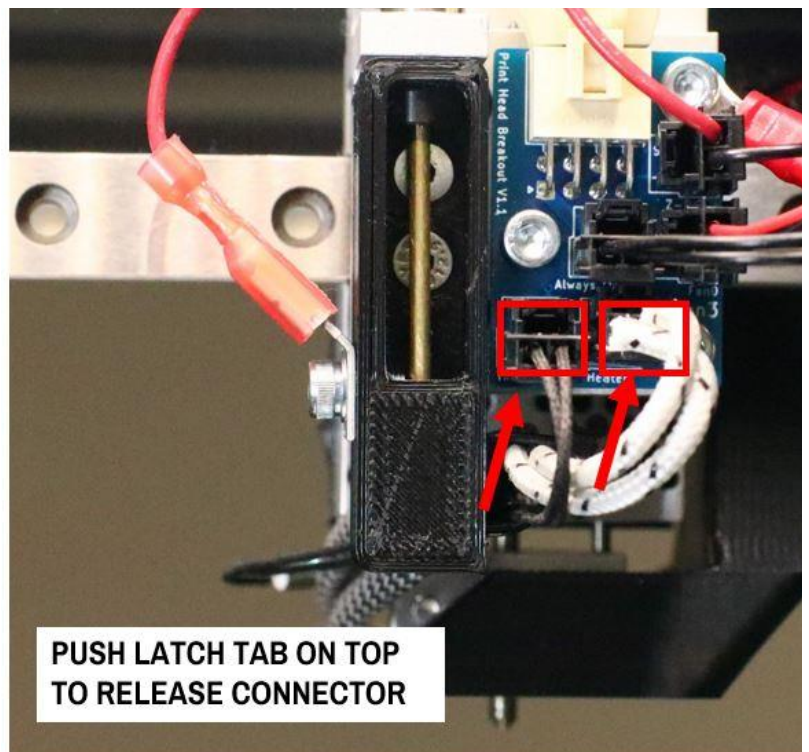

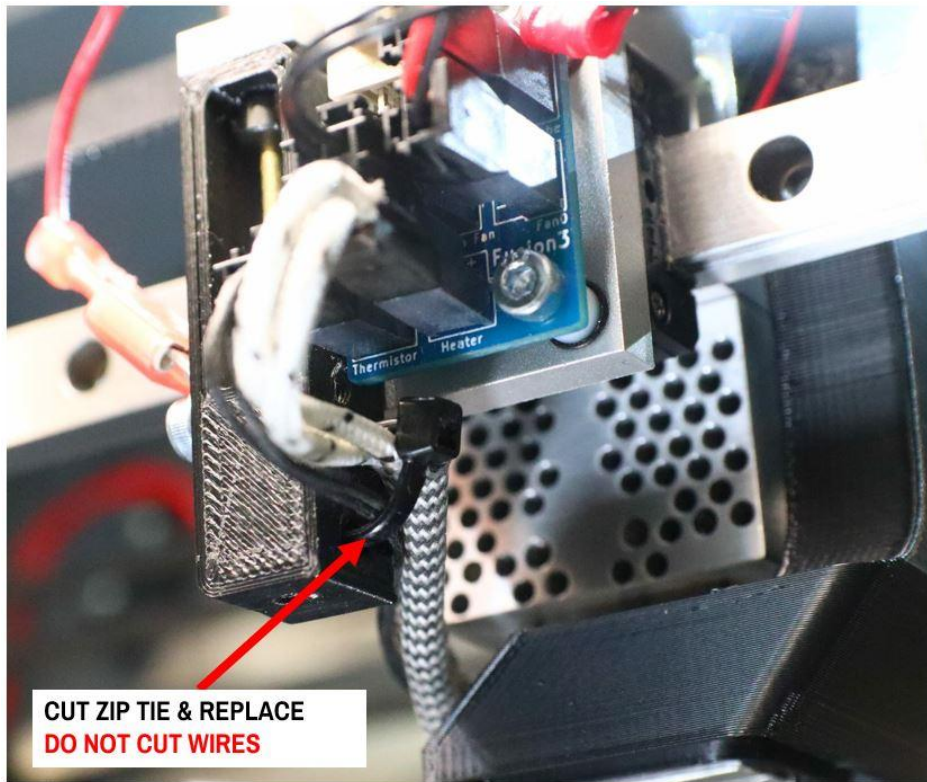

5. Once the tube is removed, completely disassemble the hot section and inspect the groove for molten plastic or other debris. Remove this with a brass wire brush. You do not want to alter the geometry of the groove as this will limit heat transfer into the tube and thus affect your printer's performance. **Therefore, do not use tools such as sandpaper, hand files, steel wire brushes, etc.**

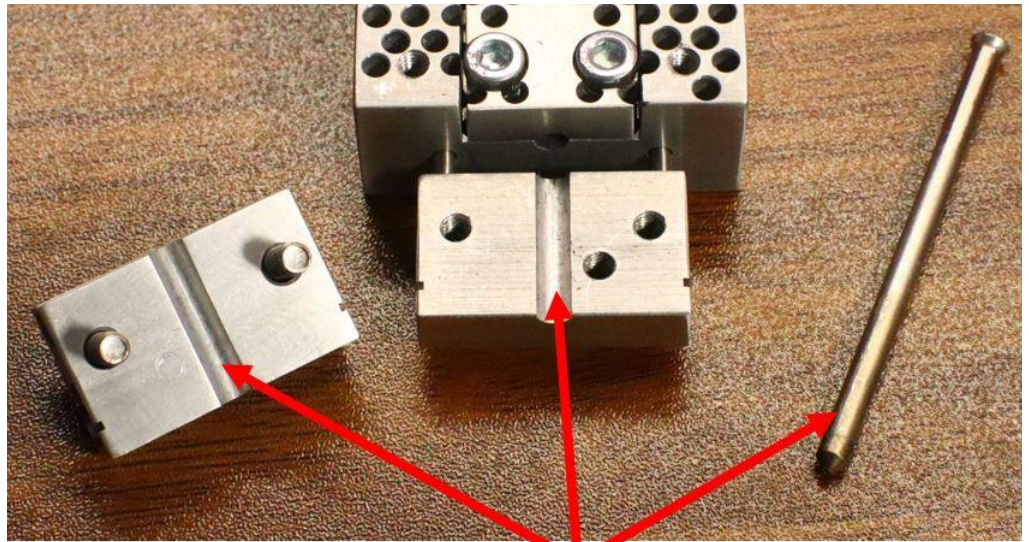

CLEAN DEBRIS FROM THESE SURFACES

INSTALLING A NEW TUBE (WITH PRINT HEAD ON THE PRINTER)

1. With no tube installed, tighten the top 2 cold side clamp screws until they bottom out, then reverse $\frac{1}{2}$ turn (90 degrees of rotation). All other clamp screws should be loose.
2. Slide the new tube down into the print head through the hole where the PTC fitting goes.
3. Push it down into place. Depending on how much debris is on the print head you may need to use a little more force. You can use a 2.5mm hex key to push it down all the way so it's recessed into the pocket as shown.

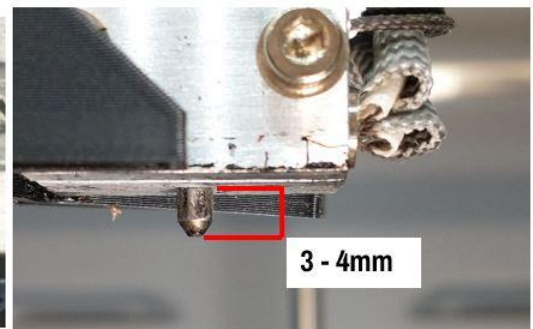
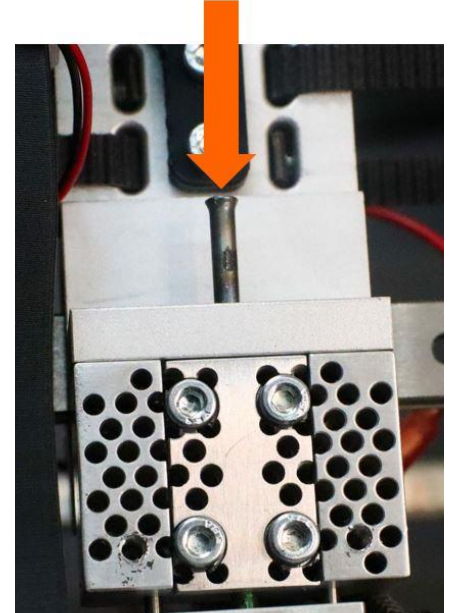

4. When fully inserted, 3-4mm of tube tip should extend out of the bottom of the hot block
5. Tighten all 6 clamp screws completely. Remember to use a non-ball-end driver on the hot side screws.

IMPORTANT: Make sure the heater and sensor are fully seated in the hot section as you tighten the screws. Equipment damage and/or a hazardous condition can develop if this is not done.

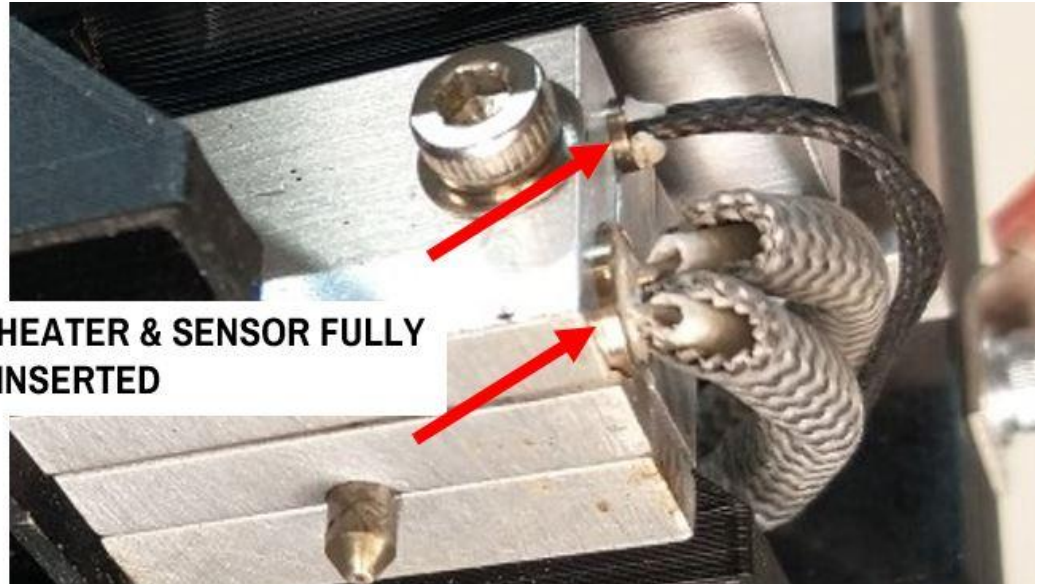

6. Re-install the cold side fan & duct.

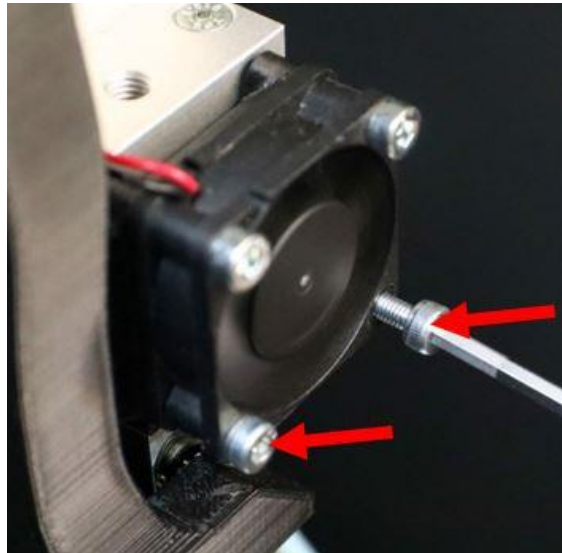

7. Re-install the blower and duct, if you removed it. Make sure the duct does not physically touch the hot block anywhere; adjust its position as needed.

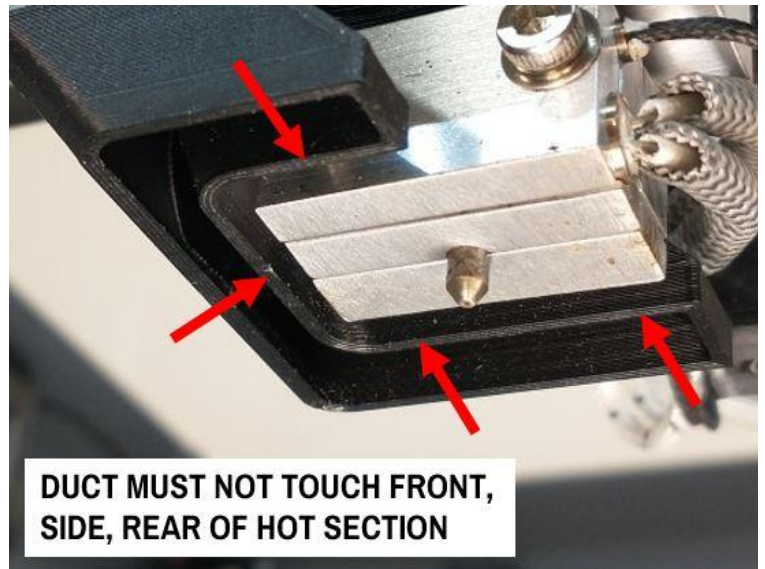

8. Reinstall the PTC fitting and the bowden tube.
Remember to replace the bowden tube if it has ANY play in the PTC fitting.

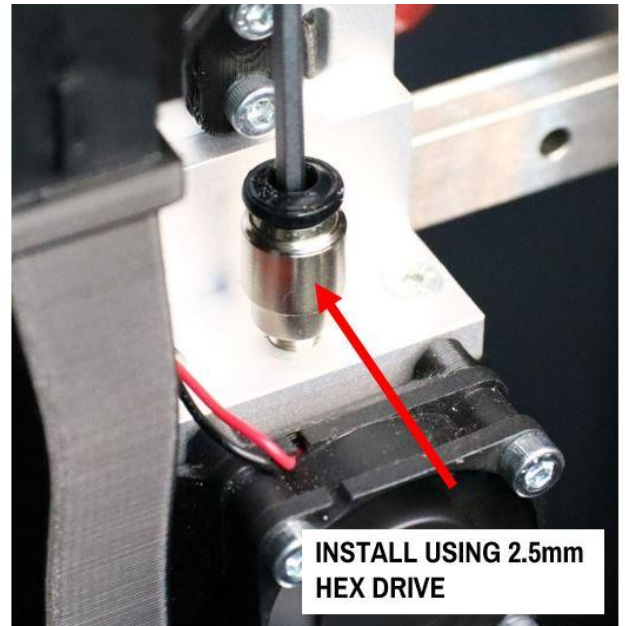

INSTALLING A NEW TUBE (WITH PRINT HEAD OFF THE PRINTER)

1. Slide the new tube into the cold section part ways.

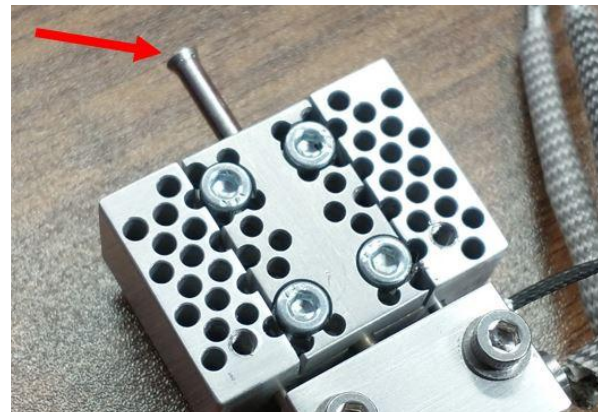

2. Tighten the top two cold side clamp screws until they bottom out, then loosen them $\frac{1}{4}$ turn each.

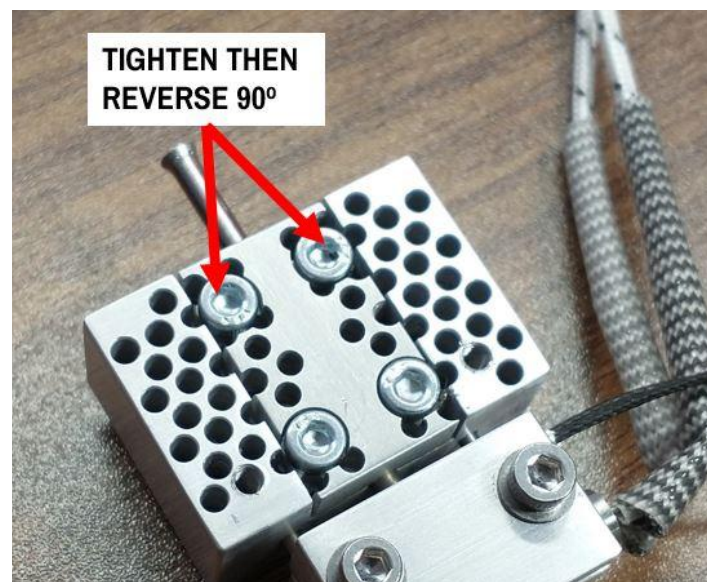

3. Now slide the tube down into the print head fully. When fully seated, the tip of the tube should protrude about 3-4mm from the bottom of the hot block.

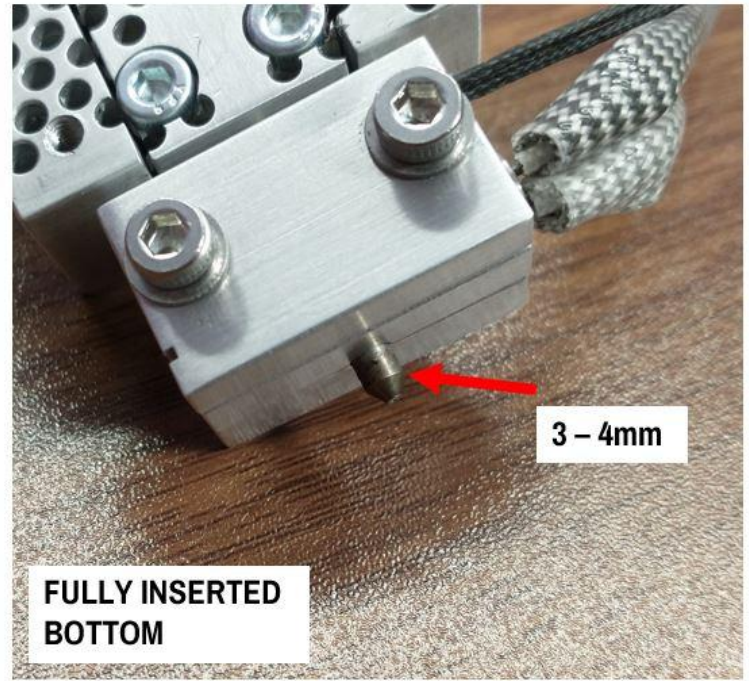

4. Tighten all (4) cold side screws and (2) hot side screws fully. Use a non-ball end drive for this so you do not round out the screws.

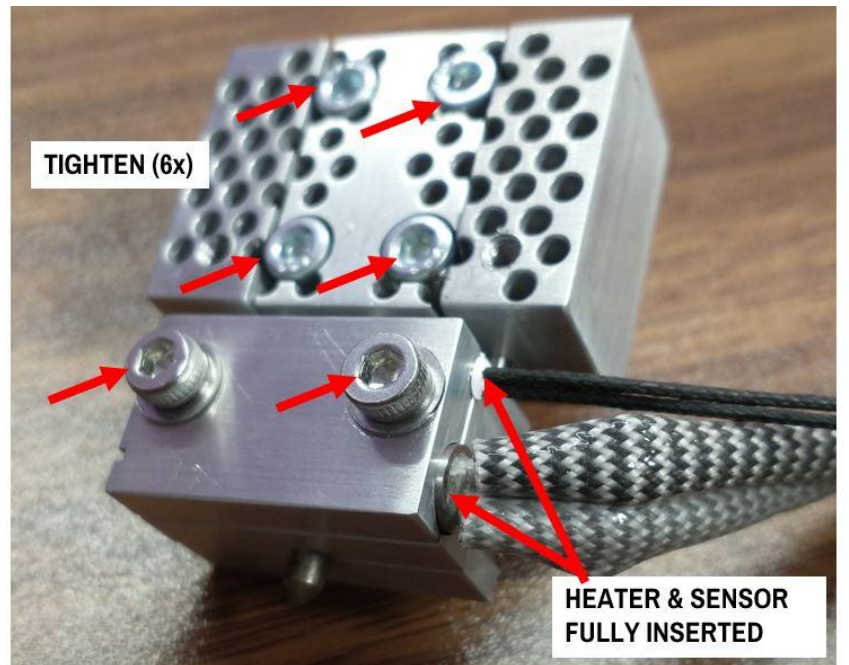

5. Re-install the 30mm fan and duct onto the cold side. If this component is still electrically attached to the printer, do this step after you have put the print head back onto the printer.

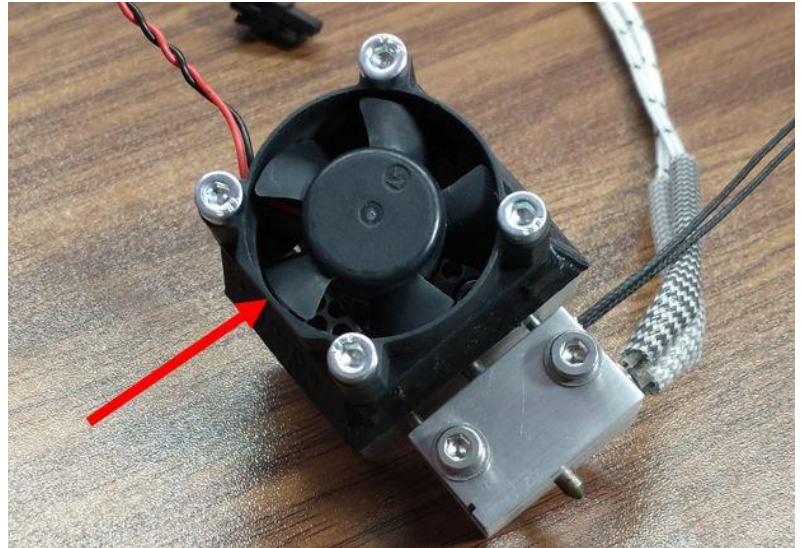

6. Re-install the print head onto the X carriage assembly.

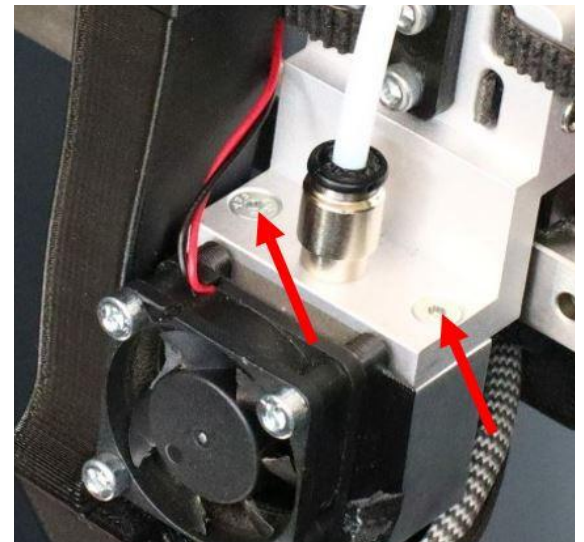

7. Reconnect the wiring: 30mm fan (if applicable), heater, sensor.

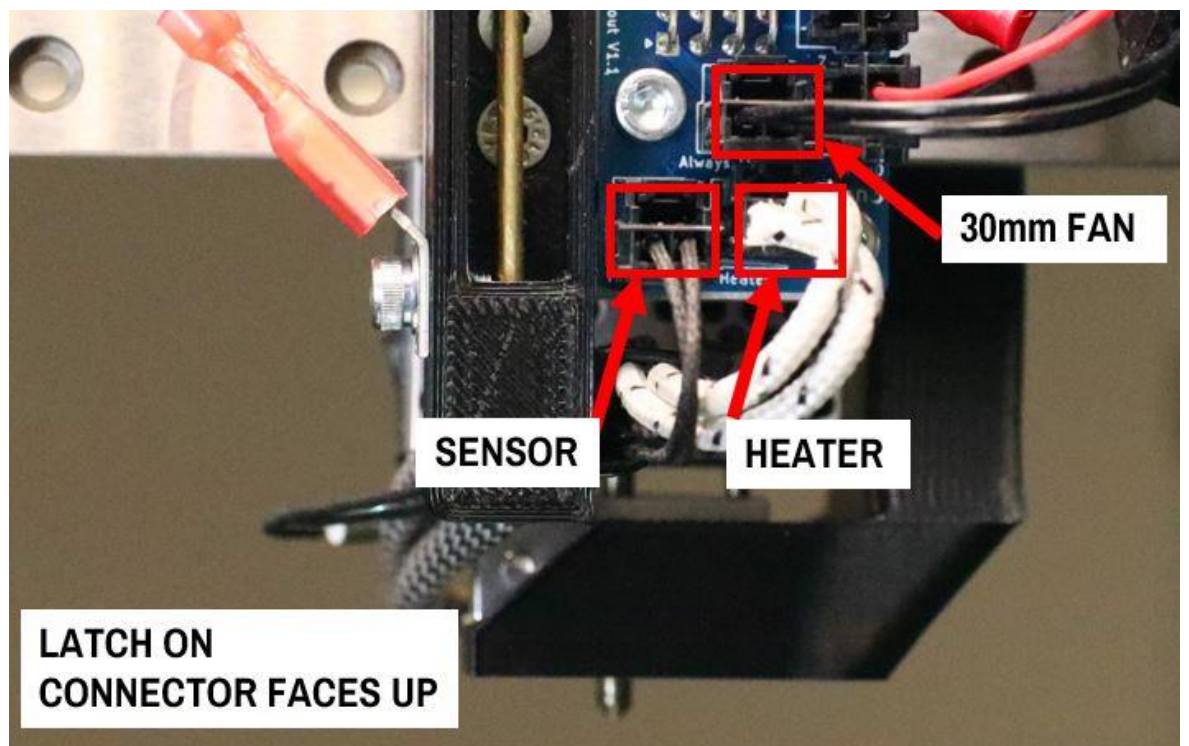

8. Re-install the blower and duct, if you removed it. Make sure the duct does not physically touch the hot block anywhere; adjust its position as needed (see picture in previous section).
9. Re-install the PTC fitting and the bowden tube. Remember to replace the bowden tube if it has ANY play in the PTC fitting.

10. Function Check:

- a. Power the printer on.
- b. Make sure you get a good (real) temperature reading from the print head.
- c. Set the print head to 200 C.
- d. Make sure it begins to heat.
- e. Make sure the 30mm fan begins to spin when the head is > 45 C.
- f. Make sure it reaches the set point without an error or fault.
- g. Turn the print head off.

Related Articles / Resources:

Tags: anvil, print head, tube, tube replacement